



State of New Jersey

DEPARTMENT OF ENVIRONMENTAL PROTECTION

Bureau of Nonpoint Pollution Control

Division of Water Quality

Post Office Box 029

Trenton, New Jersey 08625-029

609-633-7021 Fax: 609-984-2147

http://www.state.nj.us/dep/dwq/bnpc_home.htm

CHRIS CHRISTIE
Governor

KIM GUADAGNO
Lt. Governor

BOB MARTIN
Acting Commissioner

March 10, 2010

Thomas H. Happel
Suntree Technologies, Inc.
798 Clearlake Road, Suite 2
Cocoa, FL 32922

Expiration Date: May 15, 2011

TSS Removal Rate: 50%

Re: Request for Conditional Interim Certification for the Nutrient Separating Baffle Box by Suntree Technologies, Inc.

Dear Mr.Happel:

The Stormwater Management rules under N.J.A.C. 7:8-5.5(b) and 5.7(c) allow the use of manufactured treatment devices (MTDs) for compliance with the design and performance standards at N.J.A.C. 7:8-5 if the pollutant removal rates have been verified by New Jersey Corporation for Advanced Technology (NJCAT) and have been certified by the New Jersey Department of Environmental Protection (NJDEP).

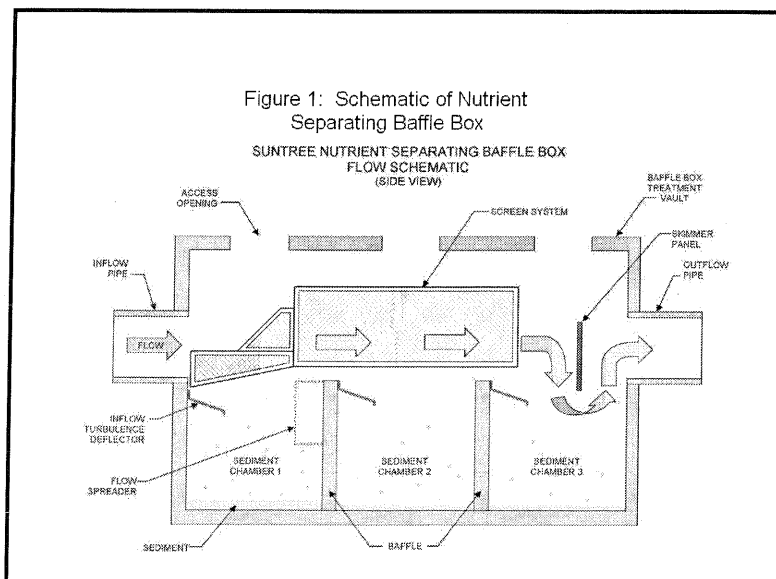

The certification process has been revised. The revised process places MTDs into five categories. The Nutrient Separating Baffle Box by Suntree Technologies qualified for Category III, MTDs with NJCAT Verification issued as of May 15, 2009.

The Nutrient Separating Baffle Box is comprised of a screen basket above the baffles within a box. Flow enters above the basket trapping large particles and above baffles and then below a skimmer panel before discharge as shown in Figure 1 above.

Figure 2

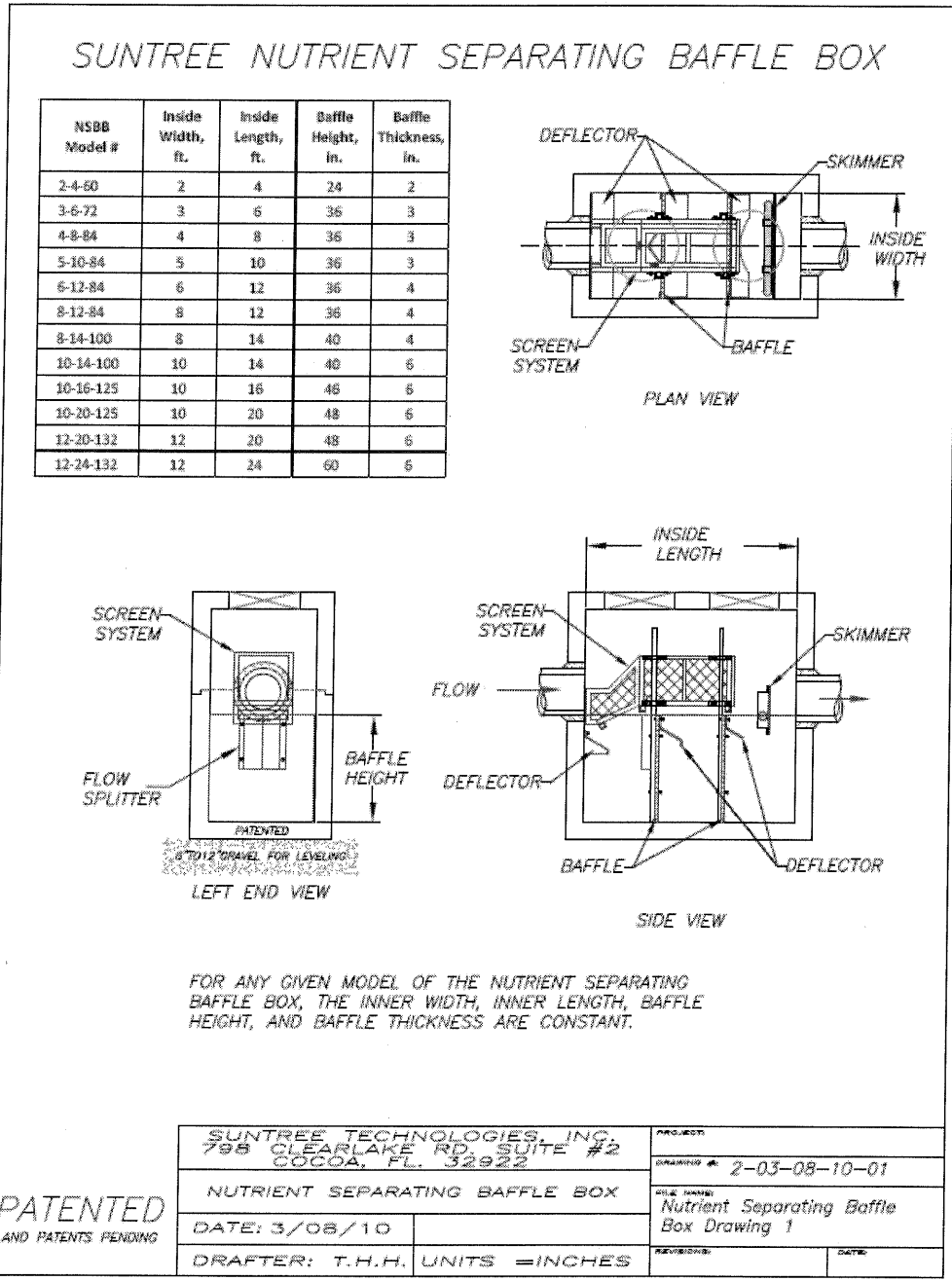

The NJDEP received the submitted data demonstrating the above approved TSS Removal Rate, a maintenance plan required under Category III, and a signed statement indicating that the maintenance portions of the 2009 NJDEP Testing Protocols as amended and supplemented (Hydrodynamic, Filter, or Field requirements in accordance with NJ Amendments of TARP) are incorporated into the maintenance plan.

Based on the NJCAT verification and the Department's review, the Department acknowledges that the requirements for this category are met; therefore, grants interim certification with an expiration date of May 15, 2011. The NJDEP certifies the use of the Nutrient Separating Baffle Box by Suntree Technologies a TSS removal rate of 50%, subject to the following conditions:

1. The various models and associated water quality flow capacities shall be sized for the peak flow of the New Jersey water quality design storm per N.J.A.C. 7:8-5, as shown in Table 1 below.

Table 1 Dimensions and Characteristics of common NSBB Models

NSBB Model #	Inside Width, ft.	Inside Length, ft.	Baffle Height, in.	Baffle Thickness, in.	Volume Plan Area, ft ²	Maximum Treatment Flowrate, cfs	Maximum Sediment Storage Volume, ft ³	Required Sediment Removal Interval, years	Minimum Sediment Storage Volume, ft ³
2-4-60	2	4	24	2	7.3	0.44	4.89	2.45	1.00
3-6-72	3	6	36	3	16.5	1.0	16.5	3.64	2.27
4-8-84	4	8	36	3	30.0	1.8	30.0	3.68	4.08
5-10-84	5	10	36	3	47.5	2.8	47.5	3.74	6.34
6-12-84	6	12	36	4	68.0	4.0	68.0	3.75	9.06
8-12-84	8	12	36	4	90.7	5.3	90.7	3.78	12.0
8-14-100	8	14	40	4	107	6.2	119	4.22	14.0
10-14-100	10	14	40	6	130	7.8	144	4.09	17.7
10-16-125	10	16	46	6	150	8.9	192	4.75	20.2
10-20-125	10	20	48	6	190	11.1	253	5.03	25.2
12-20-132	12	20	48	6	228	13.3	304	5.05	30.1
12-24-132	12	24	60	6	276	16.0	460	6.36	36.2

2. The Nutrient Separating Baffle Box is certified as an off-line system only. Any flow above the New Jersey water quality design storm must be bypassed around the system.
3. A sedimentation chamber, such as the Nutrient Separating Baffle Box, cannot be used in series with another hydrodynamic separator or settling device to achieve an enhanced removal rate for total suspended solids (TSS) removal under N.J.A.C. 7:8-5.5.
4. The maintenance plan for sites using this device shall incorporate, at a minimum, the maintenance requirements in the attached the Nutrient Separating Baffle Box Operation and Maintenance Manual.

In addition to the attached, the detailed maintenance plan must include all of the items identified in Chapter 8: Maintenance of the New Jersey Stormwater Best Management Manual. Such items include, but are not limited to, the list of inspection and maintenance equipment and tools, specific corrective and preventative maintenance tasks, indication of problems in the system, and

training of maintenance personnel. Additional operation and maintenance information associated with this manufactured treatment device is available from the vendor to assist in the development of a complete maintenance plan.

The Department anticipates proposing further adjustments to this process through future rulemaking for the Stormwater Management Rules. Additional information regarding the implementation of the Stormwater Management Rules N.J.A.C. 7:8 are available at www.njstormwater.org. If you have any questions regarding the above information, please contact Ms. Sandra Blick of my office at (609) 633-7021.

Sincerely,

A handwritten signature in black ink, appearing to read "B. Chalofsky".

Barry Chalofsky, P.P., Chief
Bureau of Nonpoint Pollution Control

c: chron file
Deb O'Brien, Lewis & Gellen, LLP.
Tom Micai, NJDEP
Mary Beth Brenner, NJDEP
NJCAT



798 Clearlake RD, Cocoa, FL 32922, Ph: 321-637-7552 FAX: 321-637-7554, www.suntreetech.com

**NJDEP Maintenance Requirements
for the Nutrient Separating Baffle Box
Manufactured by Suntree Technologies Inc.**

A. General Maintenance:

Maintenance activities include the removal of captured debris. Maintenance can be performed from outside the NSBB through access hatches installed in the vault surface above each chamber. During maintenance, the screen system hinges off to the side to give easy access to the sediment collected in the settling chambers. A vacuum truck is required for debris removal.

To insure that the Nutrient Separating Baffle Box obtains the pollutant removal certified by NJDEP, it is required that inspection of sediment accumulation be conducted two times per year, and in the event that the total sediment accumulation equals or exceeds one half of the Minimum Sediment Storage Volume (as listed in Table 1), then all accumulated sediment must be removed. A required maintenance interval of not more than two times per year has been determined for every NSBB model based on the NSBB storage volumes and NJDEP anticipated sediment loadings.

Required Sediment Removal Interval

The required interval for sediment removal for the NSBB models was calculated using the following maintenance interval equation from "Protocol for Manufactured Hydrodynamic Separation Devices for Total Suspended Solids Based on Laboratory Analysis" as corrected in September 2009:

$$RRI = (MASSV * 0.50) / (3.366 * MTFR * (RE/100)) \quad (\text{Eq. 1})$$

where RSRI = Required Sediment Removal Interval, years
MASSV = Maximum Sediment Storage Volume, ft³
MTFR = Maximum Treatment Flowrate, ft³/sec
RE = TSS Removal Efficiency, %

Equation 1 was applied to the NSBB models using the Maximum Sediment Storage Volumes and Maximum Treatment Flow Rates listed in Table 1. The Maximum Sediment Storage volumes were established as one third (i.e. 33%) of the total storage volume available in the bottom chambers of each NSBB model. The TSS removal efficiency of 67.3%, as was established in the NJCAT verification testing, was used in all calculations (NJCAT, 2008). The calculated Required Sediment Removal Intervals are listed in Table 1 and plotted in Figure 1. The Required Sediment Removal Interval is less than two times per year for all NSBB models. The Minimum Sediment Storage Volume (MISSV) for each NSBB model is listed in Table 1 and is that volume needed to contain one half year of sediment accumulation. MISSV was calculated using the calculation procedure for sediment accumulation in the *NJDEP Hydrodynamic Protocol*, as represented in Equation 2.

$$MISSV = \text{Recommended Maximum Sediment Storage Volume} \\ \times 0.50 / \text{Required Sediment Removal Interval} \quad (\text{Eq. 2})$$

Table 1 Dimensions and Characteristics of common NSBB Models

NSBB Model #	Inside Width, ft.	Inside Length, ft.	Baffle Height, in.	Baffle Thickness, in.	Volume Plan Area, ft ²	Maximum Treatment Flowrate, cfs	Maximum Sediment Storage Volume, ft ³	Required Sediment Removal Interval, years	Minimum Sediment Storage Volume, ft ³
2-4-60	2	4	24	2	7.3	0.44	4.89	2.45	1.00
3-6-72	3	6	36	3	16.5	1.0	16.5	3.64	2.27
4-8-84	4	8	36	3	30.0	1.8	30.0	3.68	4.08
5-10-84	5	10	36	3	47.5	2.8	47.5	3.74	6.34
6-12-84	6	12	36	4	68.0	4.0	68.0	3.75	9.06
8-12-84	8	12	36	4	90.7	5.3	90.7	3.78	12.0
8-14-100	8	14	40	4	107	6.2	119	4.22	14.0
10-14-100	10	14	40	6	130	7.8	144	4.09	17.7
10-16-125	10	16	46	6	150	8.9	192	4.75	20.2
10-20-125	10	20	48	6	190	11.1	253	5.03	25.2
12-20-132	12	20	48	6	228	13.3	304	5.05	30.1
12-24-132	12	24	60	6	276	16.0	460	6.36	36.2

Figure 1 Required Sediment Removal Intervals of NSBB Models

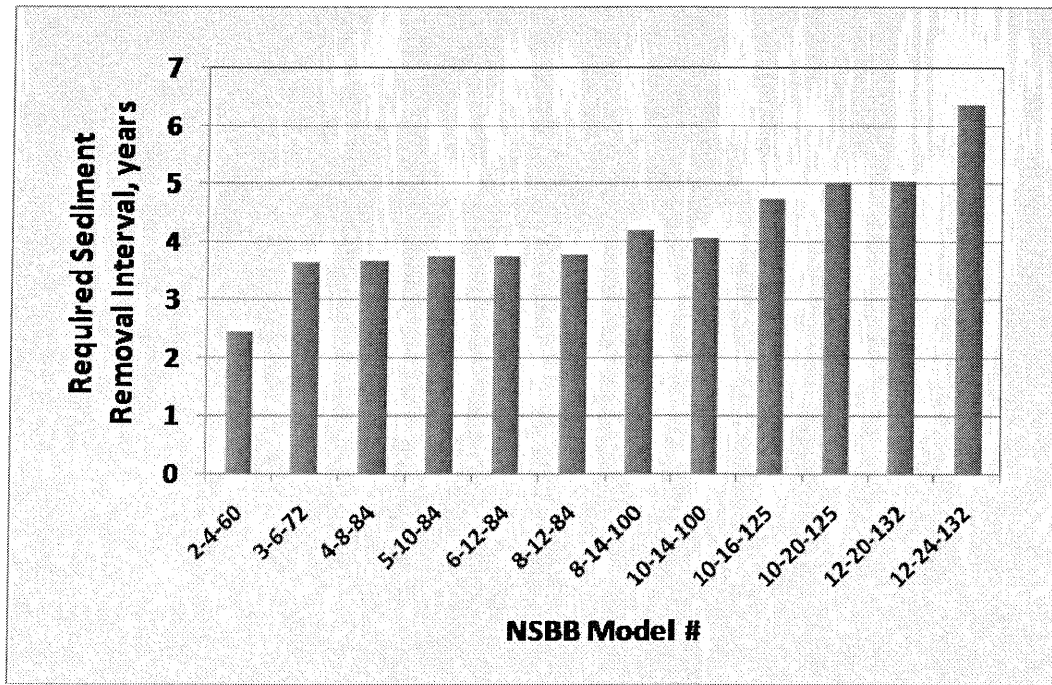

All inspection and maintenance activities should be recorded in an Inspection and Maintenance Log. Sediment, vegetation, and gross debris can generally be disposed of at the local landfill in accordance with local regulations.

Typical service procedure:

Step 1. Open the access openings on top of the Baffle Box. These access openings are typically hatches, round manhole covers, or grates.

Step 2. Vacuum the debris accumulated on the screen system until the screen system is empty.

Step 3. Open the bottom doors in the screen system to expose the sediment collection chambers. The doors are provided with eye bolts to attach a hook to lift open the doors which will hinge off to the side.

Step 4. Vacuum each of the lower sediment chambers until they are empty.

Step 5. After cleaning the sediment chambers close the bottom screen doors of the screen system.

Step 6. Visually inspect the Storm Boom in the skimmer system for oil accumulation. Change Storm Boom if it is significantly discolored or if it is close to 1 year old. The Storm Boom has ropes attached to each end which are fastened to eyelets adjacent to the access cover. These ropes act as a leash to prevent the boom from washing away, and to allow the boom to be easily pulled out of the containment bracket system on the face of the skimmer. Attach a rope on end of new boom to a rope on the end of the old boom. As the old Boom is pulled out it will pull the new boom into position. The booms will trade places. Attach the rope ends of the new boom to the eyelets adjacent to the access cover.

Step 7. When all maintenance work is completed, close the access covers.

B. Minimum Equipment requirements

A vacuum truck is required for the servicing of the Nutrient Separating Baffle Box. Safety equipment will be determined by local municipal guidelines.

C. Structural Components

The structural components are designed to have a life span of several decades. Unless local municipal guidelines require structural inspections, structural inspections are not required.

D. Replacement parts

All the interior components are designed and sized so that they can be unassembled and removed from the Nutrient Separating Baffle Box for either servicing or replacement. Replacing any of the interior components can be accomplished easily. Replacement components can be ordered by contacting:

Suntree Technologies Inc.
Ph: (321) 637 7552
www.suntreetech.com