

## Section 15

### Traffic Calming

#### 15.1 Introduction

##### 15.1.1 General

Traffic calming may be considered for Department administered or financed projects in accordance with the guidelines and requirements contained in this chapter on roadways:

- with a proposed speed limit of 35 mph or below,
- for Main Streets –all highways and streets whose adjacent land uses require accommodation of pedestrians and bicyclists, serious consideration of street aesthetics and a degree of traffic calming
- FHWA must approve of Traffic Calming Devices on all National Highway System (NHS) routes

##### 15.1.2 Objective

The Department's Statement of Design Philosophy for *Proactive Roadway Design* and Complete Streets Policy holds that "in conceiving, scoping and designing projects, the NJDOT will consider the needs of all road users of all ages and abilities. This includes pedestrians, bicyclists, residents, and businesses, as well as drivers." To accomplish this goal, specific design features known as traffic calming may be used. Traffic calming has been in the USA and other countries, shown to reduce motor vehicle speeds and increase vehicular, bicycle and pedestrian safety.

##### 15.1.3 Definition

Traffic calming is the combination of mainly physical measures that alter driver behavior and improve conditions for non-motorized street users. Traffic calming involves changes in street alignment, installation of barriers, and other physical measures to reduce traffic speeds and cut-through volumes in the interest of street safety, livability, and other public purposes.

##### 15.1.4 References

- ITE. *Traffic Calming State of the Practice*.
- ITE. *Guidelines for the Design and Application of Speed Humps*.
- Delaware DOT. *Traffic Calming Design Manual*.
- New York City DOT. *Mini-Roundabout Policy*.
- Seattle Streets Dept. *Traffic Circle Design Guidelines*.
- New York City DOT. *Neckdown Policy*.

##### 15.1.5 Principles

To be considered traffic calming, projects should have an impact on at least one of following:

###### Vehicle Speed

Vehicle speed is a significant determinant of severity of crashes, should be logical with respect to context, and is a critical factor in safety where there are conflicting traffic modes. Lower vehicle speeds open a range of design options that enable a street to look less like an expressway and more like a neighborhood street.

###### Pedestrian and Bicycle Exposure Risk

By making the distance to cross the street shorter, the time spent crossing the street is reduced and the exposure risk is subsequently reduced.

### Driver Predictability

If other street users can better predict how and where a particular vehicle will be driven, the street will be safer.

In addition, traffic calming features should be functioning all the time - 24 hours a day, seven days a week.

## 15.2 General Traffic Calming Design Controls

### 15.2.1 Design Speed

Generally, the design speed of roadways with traffic calming devices shall be equal to the posted speed limit or statutory speed of the roadway. Traffic calming devices assist in maintaining this design speed (and adherence to the speed limit) by physically limiting the speed at which the design vehicle may traverse the device. The goal is to moderate vehicle speeds along the roadway, and to improve the safety and functionality for all road users.

- Mid-block traffic calming devices (speed table, chicane, median island, and choker) should have a speed profile equal to the design speed of the roadway.
- Traffic calming devices employed at intersections and junctions (mini-roundabout, raised intersection, raised crosswalk) should have a speed profile equal to the posted speed, as these devices essentially replace traffic control devices.
- Traffic calming devices located at the end of speed zone transition areas where the speed changes from higher to lower (gateway) should have a speed profile equal to the lower posted speed.
- Traffic calming devices located at the end of speed zone transition areas where the speed changes from lower to higher (gateway) should have a speed profile equal to the higher posted speed.

As stated in the MUTCD, advanced warning signs for certain speed differentials shall be posted.

Traffic calming devices that affect turning speeds at intersections (reduced turning radii, forced turn island, diagonal diverter, median barrier, curb extension, realigned intersection) should have a speed profile of 10 mph. This is consistent with AASHTO policies, which state that vehicles turning at intersections designed for minimum-radius turns operate at low speed (less than 10 mph). Refer to *AASHTO Geometric Design of Highways and Streets* 2004 Chapter 2 for the "Minimum Turning Path's of Design Vehicles".

The appropriate turning radii are depicted in Section 6.4, Vehicular Turning Movements.

### 15.2.2 Clear Zone and Streetscape

For urban arterials, collectors, and local streets where curbs are utilized, space for clear zones is generally restricted. A minimum horizontal clearance distance of 1.5 feet should be provided beyond the face of the curb to all obstructions, with wider offsets provided where practical. The horizontal clearance will generally permit curbside parking and will not have a negative impact on traffic flow. However, a minimum clear zone distance commensurate with prevailing traffic volumes and vehicle speeds should be provided where practical.

The repetition of vertical elements such as street trees and light fixtures may serve

to moderate speeds. First, the roadway corridor is narrowed visually making it feel more intimate and confining. Second, the constant movement of vertical elements in the peripheral vision of the motorist can heighten the motorists' awareness of the surrounding environment.

### **15.2.3 Signs and Markings**

#### General Guidance

The general rule for signing and marking traffic calming devices is to install markings at the device and install advance warning signage according to the MUTCD. When there is no advance signage, signage should be installed at the device. For specific guidance, see the MUTCD or the NJDOT Standard Sign Manual.

Additional warning signs are not required under the following conditions:

1. Where one device with a similar or lower speed profile follows another by 500 feet or less. For example if speed humps are placed in a series and each is separated by 300 feet, then intermediary advance warning signs are not required. Instead, a rider indicating how far the series extends should be included with the advance warning sign before the first device in the series. Individual signage is not required for each hump.
2. Where one device with a higher speed profile follows another, but the distance is less than that listed in the MUTCD.
3. Where cross traffic enters the traffic calmed street within a series of devices.

#### Minimizing the Number of Signs

Traffic calming is by its very nature self-enforcing, self-explaining, and self-apparent. To this end, the use of signs shall be kept to a minimum. This is consistent with MUTCD policy which states: warning signs should be used conservatively because these signs, if used to excess, tend to lose their effectiveness. Fewer signs equal better aesthetics and a more context-sensitive approach to roadway design. Good aesthetics and sensitivity to context are imperative to the success of traffic calming schemes.

### **15.3 Traffic Calming Design Standards**

#### **15.3.1 Volume Control Devices**

##### Intersection Median Island

An intersection median island is a small raised median placed in the center of an intersection which physically restricts left turns and through traffic from a cross street or driveway See Figure 15-A. The effect is the same as a normal median that continues through an intersection. An intersection median island can also be designed to calm traffic on the through street.

Median islands follow the same general guidelines for medians found in Section 5.9.1. An important distinction is that traffic calming medians should be raised and dimensions are given for the raised section, exclusive of edge lines and inside shoulders.

Colored and/or textured pavement and landscaping should be considered at islands.

Median islands double as pedestrian refuge islands and shall be designed accordingly. Where there are marked crosswalks, pedestrian ramps or slips shall be provided as per ADA requirements.

If there is a specific cycling facility, it should be incorporated into the design.

EMS access should be considered in such a way as to allow careful access by EMS vehicles if appropriate.

### Forced Turn Island

A forced turn island is a traffic island, typically triangular in shape, placed at the mouth of an intersection which channels traffic to the right and restricts left and through movements. The effect is similar to an intersection median island.

Forced turn islands follow the same general guidelines for channelization islands found in Section 6.5.2.

Colored and/or textured pavement and landscaping may be considered at the island.

Forced turn islands double as pedestrian refuge islands and shall be designed accordingly. Where there are marked crosswalks, pedestrian ramps or slips shall be provided as per ADA requirements.

If there is a specific cycling facility, it should be incorporated in the design of the forced turn island.

The forced turn island and overall intersection should be designed to accommodate EMS vehicles.

Other volume control devices that are used are the following:

- Full Closure (closing of a street to through traffic at an intersection or midblock)
- Half Closure (closing of a street to through traffic in one direction at an intersection or midblock)
- Diagonal Diverter (barrier placed diagonally across an intersection that forces traffic to turn in one direction and prevents other movements)

The above volume control devices are not expected to be used to control through highways or roads under the Department's jurisdiction. They may be found to be appropriate for use on cross streets or side streets under the jurisdiction of other agencies and as part of a Traffic Calming project. For these types of devices, reference should be made to publications by others for guidance.

Recommendations for signing and pavement markings are provided in the MUTCD.

# VOLUME CONTROL DEVICE INTERSECTION MEDIAN ISLAND

FIGURE 15-A

BDC13MR-03

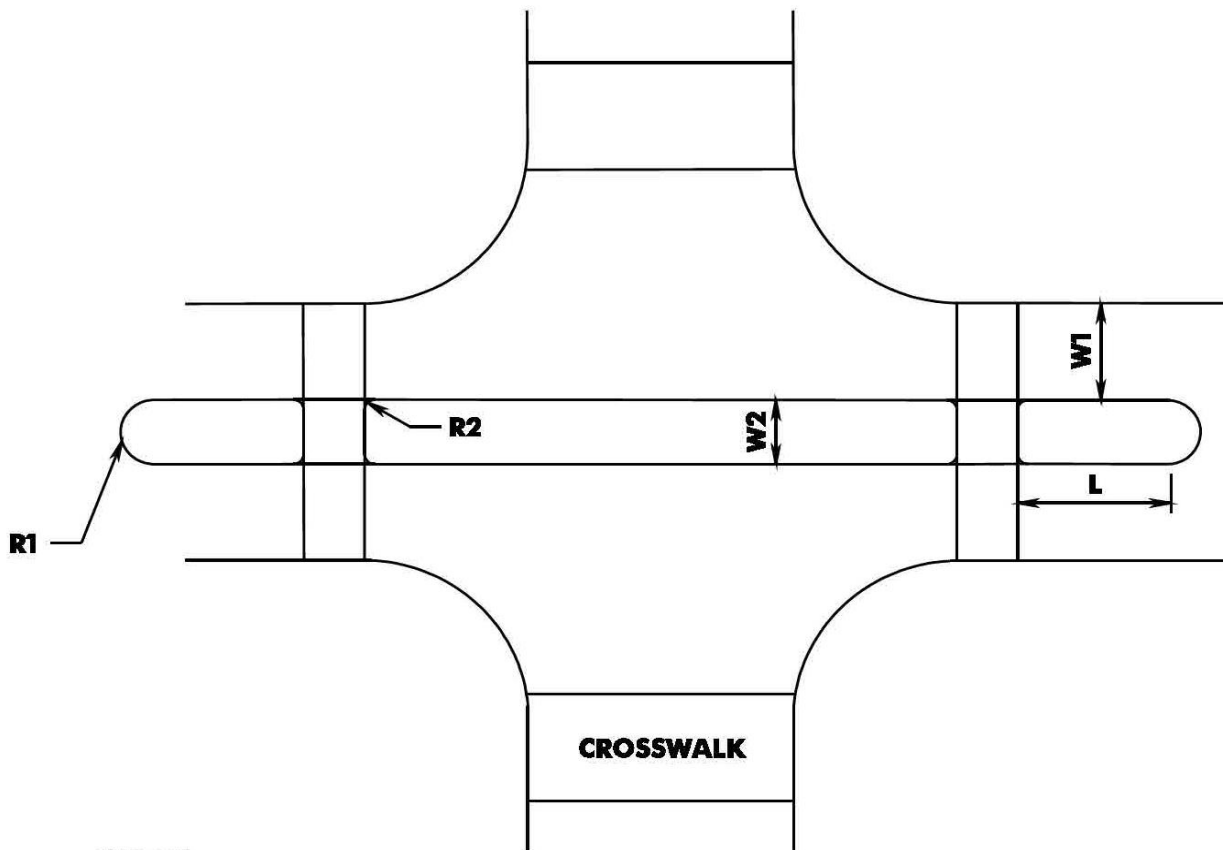

## NOTES:

1. The island should extend past the crosswalk at least 15 feet (L) to discourage drivers circumnavigating the island, and may be lengthened to coordinate with pavement, streetscape, landscape or other urban design treatments. Where there is no crosswalk, L should be measured from the corner radius point of tangent. Island could be altered to provide cut through to accommodate bikes.
2. The lane width (W1) should be sized according to the design vehicle with provision for passing a stalled vehicle.
3. The median width (W2) is desirably 8 feet with a minimum of 6 feet. It is appropriate to restrict parking, narrow travel lanes and/or alter curb lines to achieve this width.
4. The end radius (R1) is typically equal to one-half W2, but may be altered to coordinate with a pavement, streetscape, landscape or other urban design treatment.
5. The radius (R2) is desirably 4 feet, but may be altered to coordinate with a pavement, streetscape, landscape or other urban design treatment.
6. For the design of public sidewalk curb ramps and placement of the detectable warning surface, see Section 5, Major Cross Section Elements, and the Standard Roadway Construction Details.

### 15.3.2 Speed Control Devices - Vertical

#### Speed Table

A speed table is a raised area placed across the roadway designed to physically limit the speed at which a vehicle can traverse it. They moderate speed by lifting the entire wheelbase of a vehicle up from the plane of the roadway. Speed tables are placed mid-block. See Figure 15-B.

Speed tables may be constructed of asphalt, poured-in-place concrete, pre-cast concrete, brick pavers or other materials that meet the Department's criteria for roadway surfaces.

Speed tables may be constructed with sinusoidal ramps, which provide a smoother ride than flat ramps. These follow the general speed table dimensions.

Speed tables may occur as single devices or in a series. If more than 3 devices are used in a series, consideration should be given to other approaches to control vehicle speeds. The exact number will depend on the roadway context.

Speed tables may be installed on roadways with grades of up to 12 percent. On grades between eight and 12 percent the dimensions of the speed table should be altered to ensure proper performance.

A raised crosswalk is a speed table placed at a preferred crossing location. Raised crosswalks may be installed at an intersection or mid-block.

The primary difference between a speed table and a raised crosswalk is the height and manner in which it meets the curb: with or without a side taper. All other design criteria for speed tables apply. See Figures 15-C and 15-D.

The design of a raised crosswalk without a taper entails continuing the top platform onto the sidewalk and redesigning the curb drainage. Typically, an inlet is placed upstream of the raised crosswalk. The height (H) is desirably the height of the adjoining sidewalk, up to 6 inches. Longer ramps (L3) are required to maintain the proper slope as per Figure 15-C. The raised crosswalk may be lower to coordinate with a series of speed tables, or if a higher speed profile is desired. In this case a modified pedestrian ramp is used.

Detectable warning provisions (a tactile surface) shall be made to warn the visually impaired that they are entering the street, see Detectable Warnings text in Section 5.7. Vertical elements (bollards, trees, planters, street furniture) may be included in the design so that drivers do not treat a raised crosswalk as a driveway.

It is desirable to combine either type of raised crosswalk with curb extensions. All raised crosswalks should be marked.

Raised crosswalks may be stop or yield controlled if warrants are met. Advance markings are not necessary if the raised crosswalk is stop or yield controlled.

#### Raised Intersection

A raised intersection is a speed table placed in the center of an intersection. The device may exist solely within the curbs, or be combined with raised crosswalks to cover the entire intersection. A raised intersection may be placed at a T or multi-leg intersection. At these intersections, the number of ramps will coincide with the number of intersection legs and each shall be perpendicular to that leg. See Figures 15-E and 15-F.

The primary difference between a speed table and a raised intersection is the height and manner in which it meets the curb. All other design criteria for speed tables apply.

The design of a raised intersection with raised crosswalks entails continuing the top platform onto the sidewalk and redesigning the curb drainage. Typically, an inlet is placed upstream of the intersection. The height (H) is desirably the height of the adjoining sidewalk, up to a maximum of 6 inches. Longer ramps (L3) are required to maintain the proper slope, as per Figure 15-I. The raised crosswalk may be lower to coordinate with a series of speed tables, or if a higher speed profile is desired. In this case, a modified pedestrian ramp is used.

Detectable warning provisions (a tactile surface) shall be made to warn the visually impaired that they are entering the streets. Vertical elements (bollards, trees, planters, street furniture) may be included in the design so that drivers do not treat a raised intersection as a driveway.

It is desirable to combine either type of raised intersection with curb extensions.

Raised intersections may be stop or yield controlled and should include crosswalk markings.

# SPEED CONTROL DEVICES – VERTICAL SPEED TABLE

FIGURE 15-B

BDC13MR-03

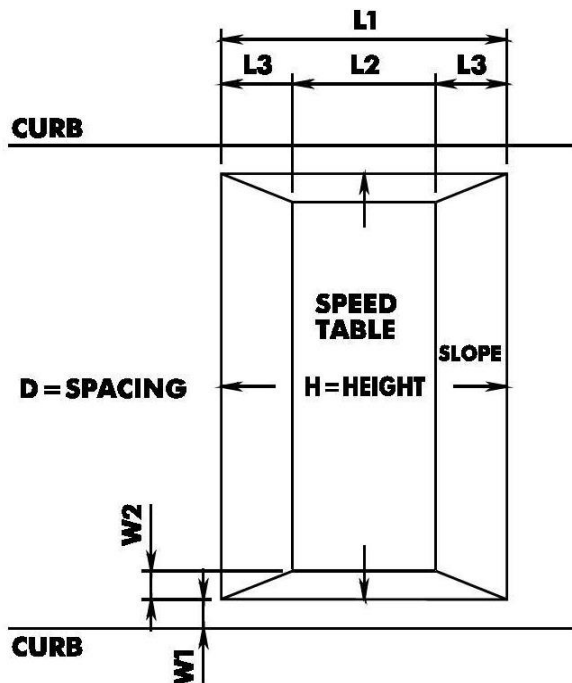

**NOTES:**

1. Curb to edge width (W1) is desirably 2 feet. Where parking is allowed full-time, this may be widened to 6 feet. Since drivers will seek to avoid traversing a speed table if at all possible, these exceptions should be kept to a minimum.
2. Where there is a marked on-street bike lane, the edge should align with the lane marking (typically 5 feet from the curb).
3. The ratio to determine the side taper width (W2) is 8:1. For a 3-inch table it is 24 inches.

4. On bus or truck routes, the overall length (L1) should be extended to accommodate the wheelbase of the design vehicle. For example, a school bus has a wheelbase of 22 feet, so the speed table would have a top length (L2) of 22 feet. The ramp lengths (L3) remain the same, but the overall length (L1) increases accordingly, up to a maximum of 50 feet.
5. The spacing (D) is given as a range for it is largely dependent on the location of driveways, curves in the roadway, roadway grade, catch basins, utility openings, and roadside features. Above all, speed tables should be located according to context. For example, if a park, school or playground abuts the roadways, then a speed table should be located at or before (in the direction of travel) the entrance to the park, school or playground. Similarly, the nighttime visibility of a speed table can be maximized by locating the speed table directly under a street light, or just after one (in the direction of travel).
6. The top of the speed table should be graded parallel to the roadway.
7. Overall length (L1) may be lengthened to coordinate with pavement, streetscape, landscape or other urban design treatment to a maximum of 50 feet.

**Speed Table Dimensions**

Speed Profile mph	H Height inches	L1 Overall Length feet	L2 Top Length feet	L3 Ramp Length feet	D Spacing feet
25	3	20	10	5	375-425
30	3	22	10	6	450-500
35	3	26	10	8	525-575



# SPEED CONTROL DEVICES – VERTICAL RAISED CROSSWALK

FIGURE 15-C

BDC13MR-03

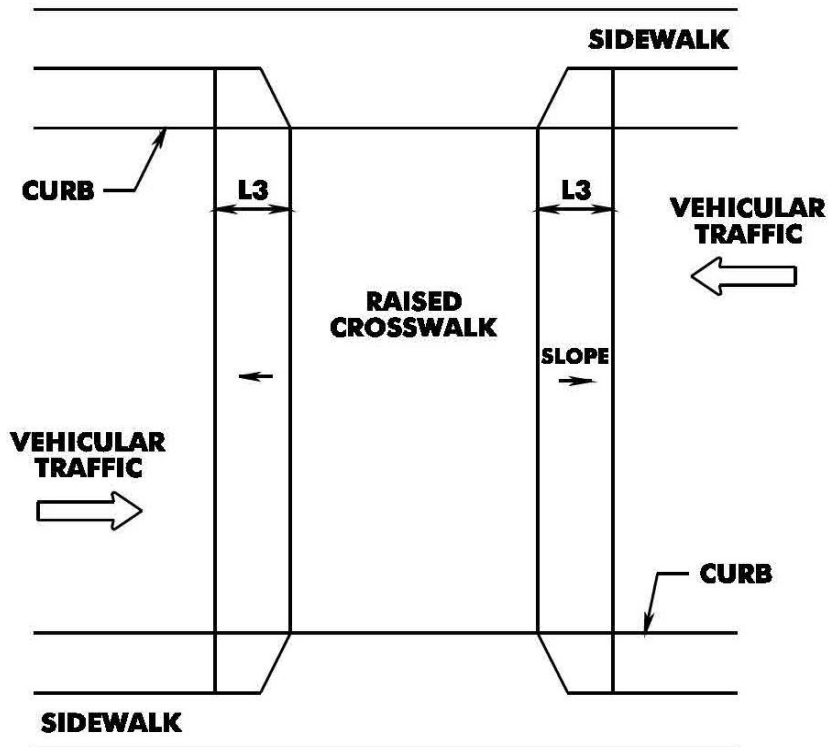

## NOTES:

1. Grade top of ramp parallel to roadway.
2. Height (H) shall be 3" high.
3. For design criteria see Figure 15-B.
4. For the design of public sidewalk curb ramps and placement of the detectable warning surface, see Section 5, Major Cross Section Elements, and the Standard Roadway Construction Details.

# SPEED CONTROL DEVICES – VERTICAL RAISED CROSSWALK WITH TAPER DIAGRAM

FIGURE 15-D

BDC13MR-03

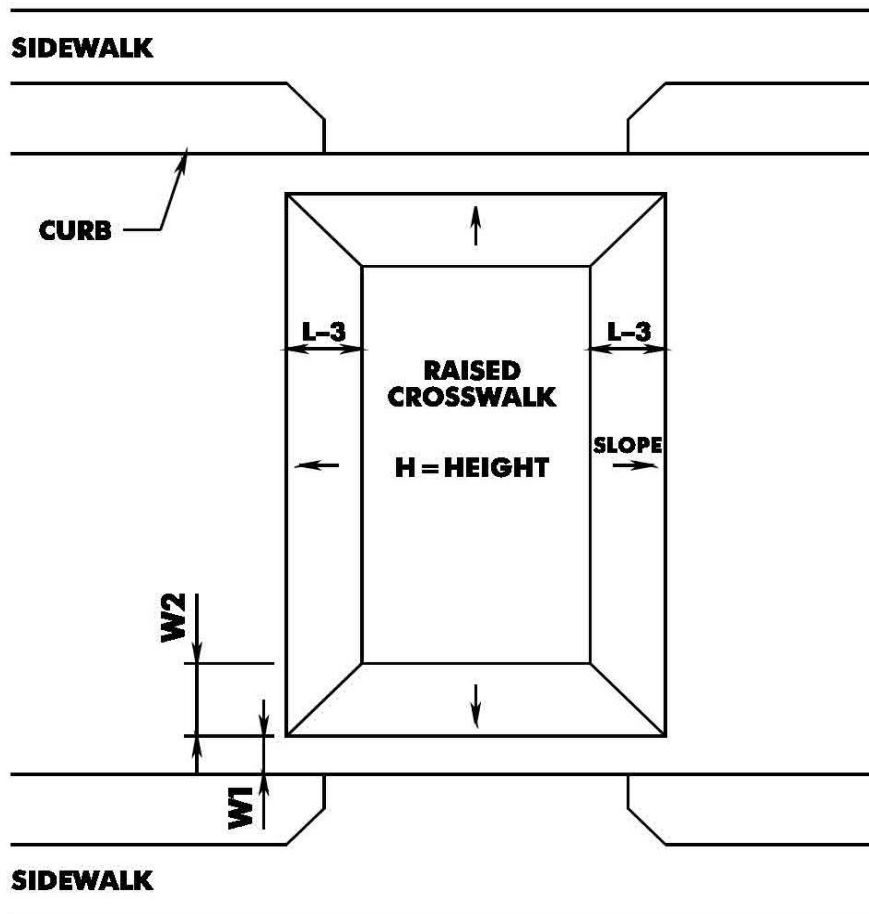

## NOTES:

1. Height (H) shall be 3 inches high.
2. The curb edge width (W1) is desirably 2 feet. Where parking is allowed full-time this may be widened to 6 feet to avoid utilities. Since drivers will seek to avoid traversing a table if at all possible, these exceptions should be kept to a minimum. Where there is a marked on-street bike lane the edge should align with the lane marking (typically 5 feet from the curb).
3. The ratio to determine the side taper width (W2) is 12:1 maximum. For a 3-inch raised crosswalk, it is 36 inches minimum width.
4. Grade top of crosswalk parallel to roadway.
5. For design criteria such as ramp width (L3), see Figure 15-B.
6. For the design of public sidewalk curb ramps and placement of the detectable warning surface, see Section 5, Major Cross Section Elements, and the Standard Roadway Construction Details.

# SPEED CONTROL DEVICES – VERTICAL RAISED INTERSECTION

FIGURE 15-E

BDC13MR-03

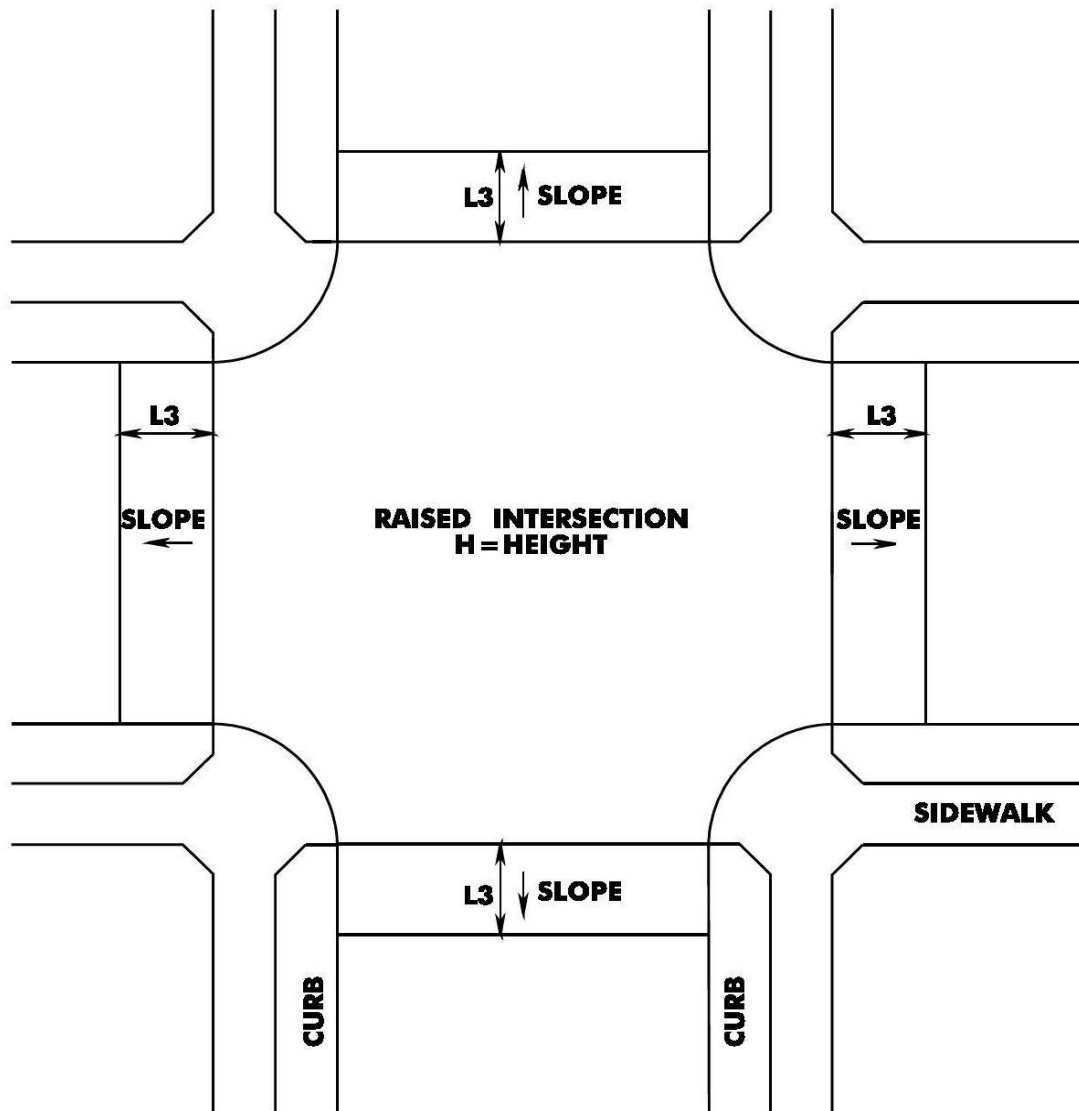

## NOTES:

1. Grade top of raised intersection parallel to main roadway.
2. Use Figure 15-B notes for dimensions.
3. For the design of public sidewalk curb ramps and placement of the detectable warning surface, see Section 5, Major Cross Section Elements, and the Standard Roadway Construction Details.

# SPEED CONTROL DEVICES – VERTICAL RAISED INTERSECTION CENTER ONLY

FIGURE 15-F

BDC13MR-03

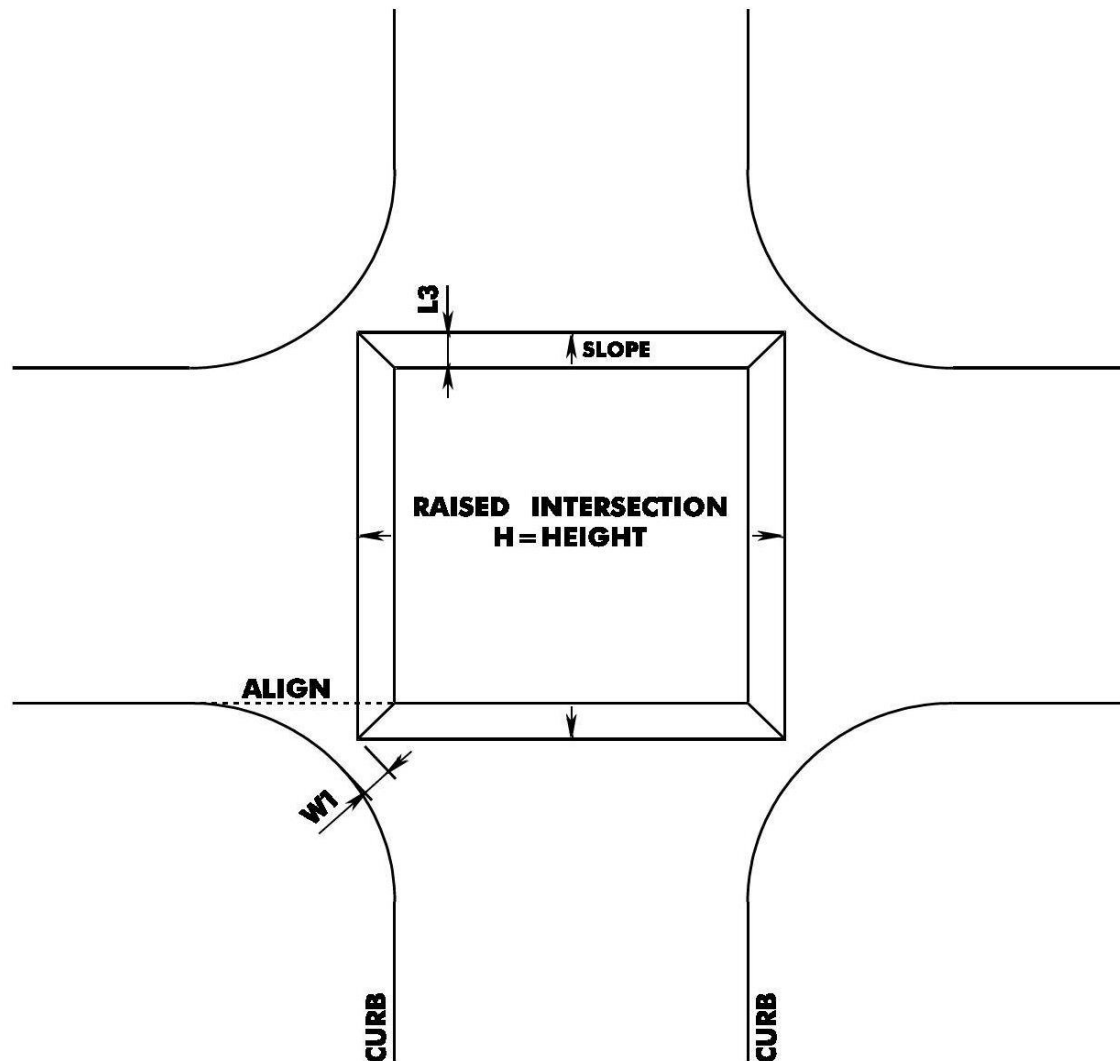

## NOTES:

1. Height (H) shall be 3 inches.
2. The primary design control is the curb to corner width (W1). This is desirably 2 feet and establishes the size of the raised intersection. If possible, the top of the table should align with the gutter line
3. For design criteria such as ramp width (L3), see Figure 15-B.
4. Grade top of raised intersection parallel to main roadway for appropriate drainage.
5. For the design of public sidewalk curb ramps and placement of the detectable warning surface, see Section 5, Major Cross Section Elements, and the Standard Roadway Construction Details.

### 15.3.3 Speed Control Devices - Horizontal

#### Roundabout

A roundabout is a circular, raised traffic island placed within the intersection of two or more streets. It operates on the “yield-on-entry” principle. Drivers circumnavigate the island in a counter-clockwise direction. Roundabouts limit speeds by horizontally deflecting vehicles as they pass through an intersection. They reduce crashes by separating movements and reducing speeds.

At multi-leg, non-perpendicular, or larger intersections, it may be necessary to modify the corner radii, utilize curb extensions, or splitter islands and install splitter islands to achieve the desired speed profile while accommodating the design vehicle. For geometric guidance, see *Roundabouts: An Information Guide*, FHWA.

Roundabouts should be constructed in the same manner as other raised islands and medians. To accommodate SU trucks and buses, the entire circle may be made mountable or the outside portion of the circle may be designed as a truck apron with a sloping curb. The radius of the apron is defined by the sweep of the design vehicle. The intersection may require re-grading to ensure proper drainage and to prevent ice build up at the circle.

Colored and/or textured pavement and landscaping should be considered at a roundabout, especially vertical elements (trees, bollards, planters) which draw attention but do not reduce sight lines.

On-street bicycle lanes should end before a roundabout so that cyclists mix with traffic. Bicycle lanes should not be marked within the circulatory roadway. Off-street bicycle facilities should be routed around the intersection entirely or may be terminated before the intersection so that cyclists mix with traffic.

See MUTCD for signs and markings.

#### Realigned Intersection

A realigned intersection refers to the redesign of an intersection for safety or traffic calming purposes. The most common realignment converts a Y- to a T-intersection.

The goals of a redesigned intersection include:

- Slower vehicle turns
- Better sight lines for traffic
- Reduced crossing distances for pedestrians
- Pedestrian refuge areas between different traffic directions
- More predictable driver behavior
- More predictable operating space for cyclists
- Improved stop or yield compliance, especially at crosswalks

Typically, these goals can be met by squaring off the intersection. See also Section 6.5, Channelization, and appropriate exhibits from ‘A Policy On Geometric Design of Highways and Streets’, AASHTO.

#### Reduced Turn Radius at Intersection

It is desirable to include a reduction in turning radii and curb extensions in a realigned intersection.

A reduced turn radius refers to using a smaller turning radius (or radii) at an intersection to slow turning traffic and reduce the crossing distance. A reduced turn

radius may be accomplished by tightening the corner radius, installing a curb extension, and/or installing a median or island.

The most successful layouts, such as setting the stop line back from a signalized intersection and out of the sweep path safely accommodate the design vehicle while ensuring that smaller vehicles turn slowly.

### Chicane

A chicane is a series of alternating curves or lane shifts (caused by placement of obstacles) located to force the driver to steer back and forth out of the normal travel path. The horizontal displacement moderates vehicle speeds. See Figure 15-G.

The chicane islands should be constructed in the same manner as other raised islands and medians.

Chicanes may be used on one-way, one-lane local roads. On two-way, two-lane roadways a chicane should be combined with a median island so that drivers do not simply steer across the centerline.

If the lane shifts or curves are placed at a distance greater than that listed in Figure 15-G, the device is known as a single lane shift or a half-chicane. These may be used on one-way two-lane roadways with volumes of 15,000 ADT and above. These should be limited to signalized roadways where the vehicle platoons will force most drivers to not cross the lane line.

Chicanes may be created by alternating on-street parking or by alternating left and right-turn lanes. These should be augmented with curb extensions if on-street parking demand is less than 50% during the off-peak period.

Landscaping may be used on low speed roads with on-street parking or where the clear zone is not violated, especially vertical elements (trees, bollards, signs) which draw attention but do not reduce sight lines

### Mid-block Median Island

A mid-block median island is a short raised median which narrows the roadway in the middle of a block See Figure 15-H. The traffic calming effect is similar to a chicane; a median island and a choker can work together to create a chicane. Median islands often double as pedestrian refuge islands. Where there are mid-block crosswalks is it desirable to locate the median island at the crosswalk.

Median islands follow the same general guidelines for medians found in Section 5.9. An important distinction is that traffic calming medians are raised and dimensions are given for the raised section, exclusive of edge lines and inside shoulders.

Colored and/or textured pavement and landscaping should be considered at a median island.

When there is a bike lane adjacent to the approach of a mid-block island the bicycle lane shall end at the beginning of the taper and cyclists shall merge with traffic.

### Choker

A choker is a set of two curb extensions placed directly opposite each other, which narrow the traveled way. See Figure 15-I. In a choker on a two-way, two lane roadways, vehicles are able to pass each other without conflict, yet the narrower crosssection makes the margin of error less for drivers. This tends to make drivers moderate their speed. Where used on a two-way street, consideration should be given to combining a double lane choker with a median island, as this will reduce the possibility of conflicts with opposing traffic.

A choker may be detached from the curb so that drainage is unaffected.

Colored and/or textured pavement and landscaping should be considered at a choker, especially vertical elements (trees, bollards, planters) which draw attention but do not reduce sight lines.

When there is a bike lane adjacent to the approach of a mid-block island, the bike lane shall end at the beginning of the taper prior to the device and cyclist shall merge with traffic.

# SPEED CONTROL DEVICE – HORIZONTAL CHICANE

FIGURE 15-G

BDC13MR-03

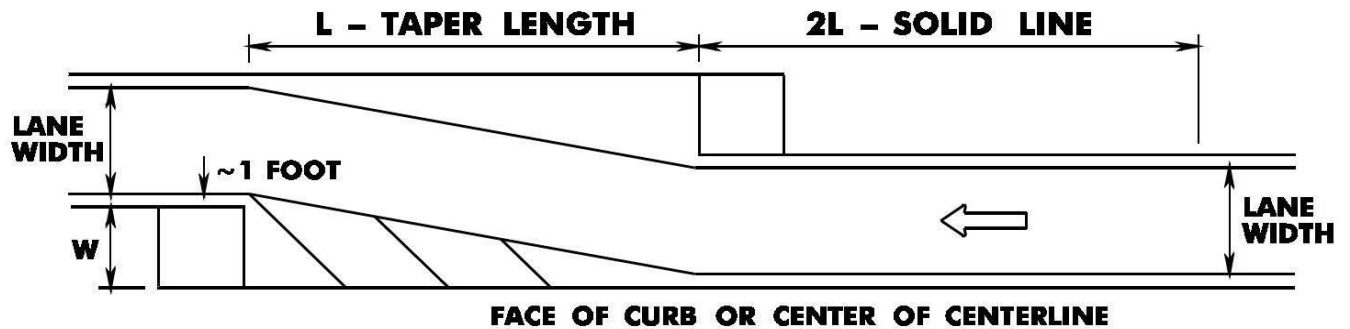

**NOTES:**

1. The offset width (W) has a minimum of 6 feet. Where there are no lane markings, the actual operating space between parked cars and/or curb should be used.
2. The taper length (L) is determined from the formula:

$$L = \frac{WS^2}{60}$$

where L is length of taper in feet, W is width the vehicle is forced to shift in feet, and S is desired speed profile in mph.

**Taper Lengths**

Speed Profile mph	W Offset Width feet						
	6	7	8	9	10	11	12
	L Taper Length, ft						
25	27	33	40	47	53	60	67
30	42	52	63	73	83	94	104
35	60	75	90	105	120	135	150



# SPEED CONTROL DEVICES – HORIZONTAL MIDBLOCK MEDIAN ISLAND

FIGURE 15-H

BDC13MR-03

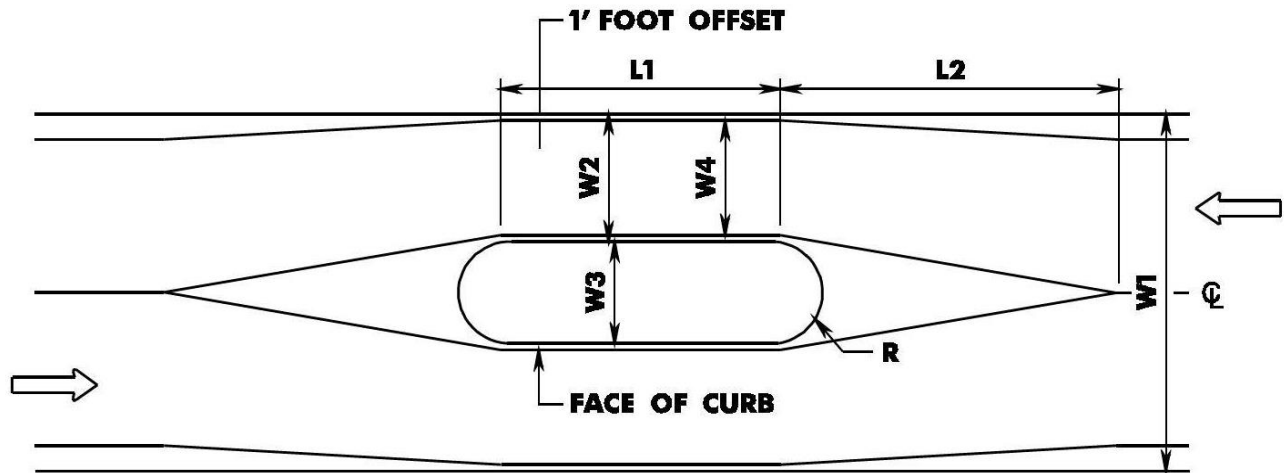

## NOTES:

1. The roadway width (W1) varies.
2. The opening width (W2) is 12 feet.
3. The island width (W3) is desirably 8 feet with a minimum of 6 feet.
4. The lane width at the island (W4) is 10 feet.
5. The length (L1) is desirably 20 feet. It may be shortened or lengthened to coordinate with pavement, streetscape, landscape or other urban design treatments, to a maximum of 50 feet.
6. The taper length (L2) is as per Figure 15-G.
7. The island radius (R) is typically equal to one-half W3, but may be altered to coordinate with a pavement, streetscape, landscape or other urban design treatment.

# SPEED CONTROL DEVICES – HORIZONTAL CHOKER – DOUBLE LANE

FIGURE 15-I

BDC13MR-03

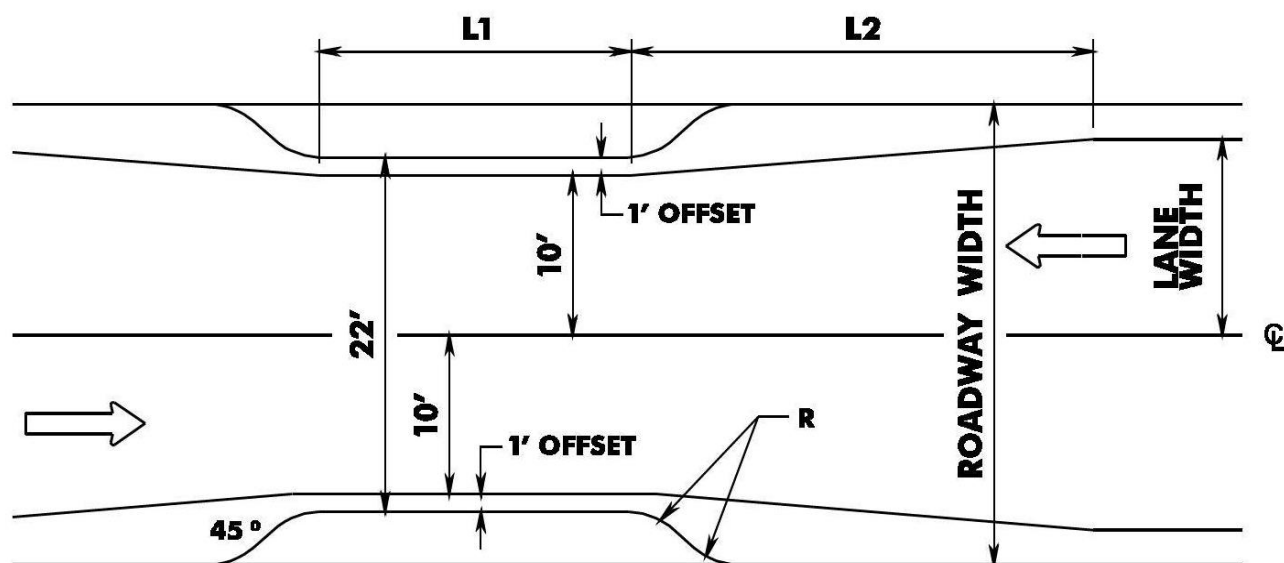

## NOTES:

1. The length (L1) is desirably 20 feet. It may be shortened or lengthened to coordinate with pavement, streetscape, landscape or other urban design treatments, to a maximum of 50 feet.
2. The taper length (L2) is as per the Table in figure 15-G.
3. The return angle is 45 degrees.
4. The radius is a desirable 4 feet but may be altered to coordinate with pavement, streetscape, landscape or other urban design treatments.

### 15.3.4 Other Devices

#### Curb Extension

A curb extension is a horizontal extension of the sidewalk into the street resulting in a narrower roadway section. See Figures 15-J. This device may be used at either corner or mid-block. Curb extensions may only be used where there is full-time on-street parking upstream of the extension.

Curb extensions are used to:

- Reduce crossing distance for pedestrians.
- Increase space for queuing pedestrians.
- Provide space for pedestrian ramps, and to align them directly with the crosswalk.
- Reduce the space available for dangerous driving maneuvers (passing on the right).
- Slow turning vehicles.
- Self-enforce truck turning prohibitions.

Curb extensions shall be offset from the through traffic by 1.5 feet. This offset is created so cyclists or drivers do not come upon the curb extension unexpectedly.

Curb extensions should be designed so that they do not intrude on bicycle operating space. Mid-block curb extensions have not proven to slow traffic, so they are not recommended to be used for this purpose.

Where there is an existing or planned mid-block crosswalk, curb extensions should be considered.

Specific signs and markings are not required for curb extensions. However, some type of vertical element (tree, bollard, planter, MUTCD object marker OM2-2V) should be installed to alert snow removal vehicle operators.

#### Narrowed Lane

Narrower lanes have been proven to decrease vehicular speeds. Narrower lanes reduce pedestrian crossing distances and subsequent exposure risk. They allow for a more efficient use of limited right of way widths in urban settings. This provides a benefit when balancing service levels across various modes.

A minimum 10' lane may be used in traffic calming areas. Provisions should also be made for cyclists.

#### On-street Parking

On-street parking calms traffic by narrowing the roadway and introducing side friction to the traffic flow. For traffic calming designs, the width of a parallel parking lane should be designed so that the minimum lane width of 10 feet is achieved.

#### Bicycle Lane

On-street bicycle lanes may calm traffic by reducing lane width or removing a lane of traffic. Colored bike lanes may enhance this effect.

#### Colored and Textured Pavement

Varying the pavement color and/or texture of the roadway accentuates a traffic calming scheme and provides visual and/or sensory cues to drivers and other street users. Typical applications include medians, parking lanes, bus lanes, bicycle lanes, no parking zones, curb ramps, and crosswalks. Textured pavement at crosswalks should be designed with mobility and sight impaired pedestrians in mind. Certain textures may be difficult to traverse with a wheelchair, walker, canes or crutches

because of uneven, heavily textured or rough surfaces, or gaps in pavement texture, i.e. spaced unit pavers or certain stamped pavement patterns. Such materials should be reserved for borders and decorative accents located outside of the pedestrian crosswalk. The preferred method is to keep a smoother texture in the center 4' minimum width and a rougher texture running along the sides of the crosswalk. Colored shoulders, parking or bicycle lanes visually narrow the roadway. Colored or textured pavement does not measurably affect vehicle speed and is recommended to be used in combination with other treatments.

#### Transverse Rumble Markings

Rumble markings are placed across the lane and cause physical and audible vibrations when driven across. This device consists of three sets of five double layered stripes placed 24 inches on center (See Figure 15-K). This alerts the motorist to an upcoming condition or device, which requires additional attention or a change in driving behavior (toll booths, stop sign, school zone, reduced speed zone, shoulder). Rumble markings are slightly raised elements on the pavement. In advance of the first set of markings, an 8-foot message (SCHOOL, REDUCED SPEED AHEAD, etc.) may be placed on the roadway.

Rumble markings do not measurably affect vehicle speed and should only be used to alert or warn motorists. They may not be suitable in areas sensitive to road noise (residential, hospital, historic). Rumble markings should not extend into the space where the cyclist normally operates, e.g., bike lanes, shoulders, shared parking lanes or wide curb lanes. Where there is no bike lane or shoulder, provide a 4 foot maximum and 3 foot minimum clear distance between rumble stripe and edge of pavement.

Designers are to develop quantities for the transverse rumble markings under the item TRAFFIC MARKINGS, THERMOPLASTIC, Square Foot. Each layer of markings is calculated for the total square footage. A construction detail is to be developed as per Figure 15-K and a note describing payment.

#### Forced Perspective

A forced perspective is a distinctive striping pattern, intended to make drivers feel that they are traveling faster than they actually are. It is configured as a series of transverse strips, which get sequentially closer together and increase in length as one travels along the street. It is used as advance warning before a traffic calming device or as part of an overall streetscape treatment. Forced perspectives by themselves do not measurably affect vehicle speed and should only be used in advance and in combination with other treatments.

The advance warning forced perspective striping pattern is detailed in the MUTCD.

As an overall streetscape treatment, the pattern shown in the MUTCD may be replicated by vertical elements adjacent to or above the roadway. Typical elements include trees, bollards, posts and overhead gantries located in accordance with section 15.2.2.

### **15.3.5 Combination Treatments**

Combining traffic calming treatments will often improve their overall effectiveness.

#### Gateway

A gateway is a combination of devices installed at the beginning of a traffic calming area. Gateways alert drivers to changed conditions and physically force them to alter their driving behavior. They typically consist of curb extensions, chokers, textured pavement, chicanes, roundabouts, speed tables, narrowed lanes, etc. Rumble stripes, a forced perspective, warning signs, etc may precede them.

# OTHER CONTROL DEVICES CORNER CURB EXTENSION

FIGURE 15-J

BDC13MR-03

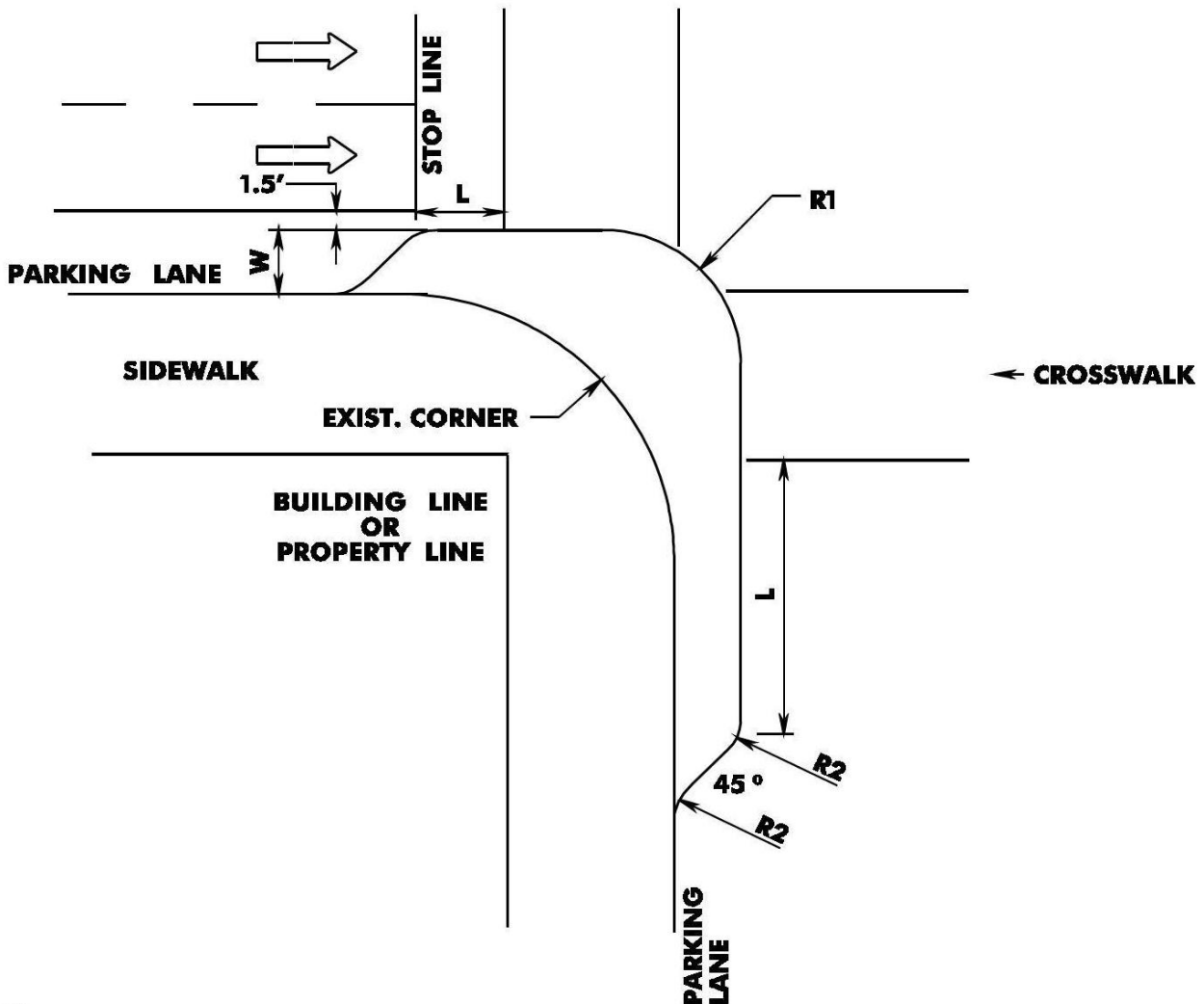

## NOTES:

1. The corner radius (R1), typically 10–15 feet, is based on the inside turning radius of the design vehicle and desired turning speed.
2. The width (W) is equal to the width of the parking lane minus 1.5 feet. The return angle is 45 degrees.
3. The distance between the crosswalk and the return (L) varies and should be coordinated with the pavement, streetscape, landscape or other urban design treatment. For example where there is a stop line L should be extended to it. Where a fire hydrant is within 40 feet of the crosswalk (or extension of the property/building line), L may be extended so that the hydrant may be relocated onto the curb extension. L may also be lengthened to accommodate street furniture, bus shelters, sidewalk cafes or other roadside uses, to increase stopping sight distance, or to provide a clear corner zone.
4. The radius (R2) is desirably 4 feet, but may be altered to coordinate with a pavement, streetscape, landscape or other urban design treatment.
5. For the design of public sidewalk curb ramps and placement of the detectable warning surface, see Section 5, Major Cross Section Elements, and the Standard Roadway Construction Details.

# TRANSVERSE RUMBLE MARKINGS

FIGURE 15-K

BDC13MR-03

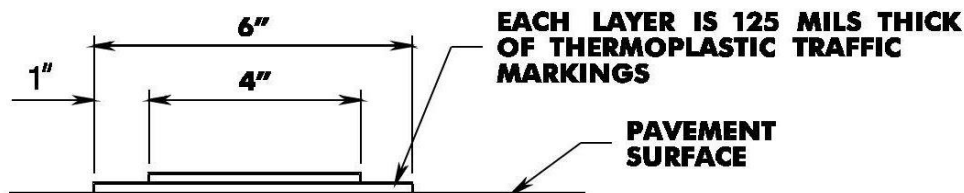
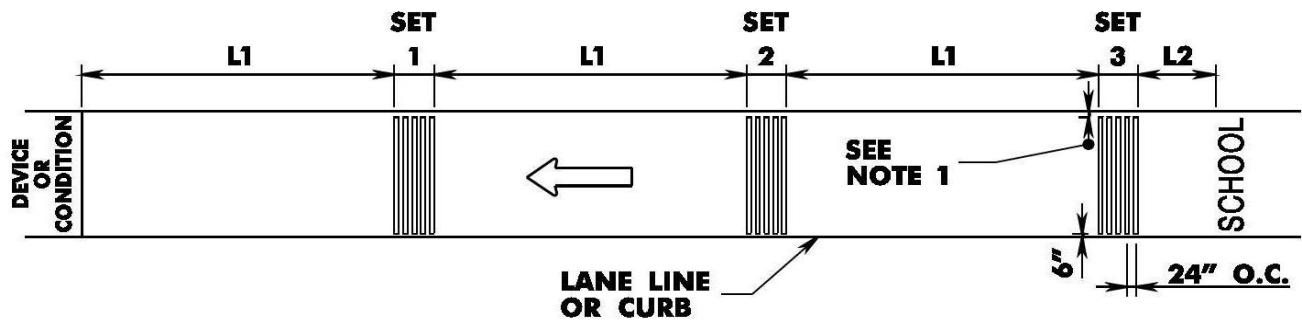

**RUMBLE MARKING DETAIL**

**NOTE:**

1. Where there is no desirable bike lane or shoulder, provide 4 ft. desirable and 3 ft. minimum clear distance between rumble marking and lane line or curb.
2. Installation consists of three sets of five markings.

**Rumble Marking Spacing**

Posted speed at upcoming condition or element, mpg	L1 Distance between sets, ft	L2 Distance between first set and message in roadway, ft
25	75	20
30	85	25
35	95	30