

**New Jersey Department of Transportation  
QUALITY IMPROVEMENT ADVISORY**

**QUALITY MANAGEMENT SERVICES**

**Manager: Brian Strizki**

**Telephone: (609) 530-6363**

**QIA No. QIA021**

**Approved: B. Strizki**

**Date: 9/28/1999**

**Process Affected:**

Scope    Design    Right of Way    Utilities    Environmental    Historic    Construction

**Bureaus Affected:** All CPM Units  
All Design Consultants

**Procedure(s) Affected:** Design Development  
Construction

**Route & Section:** N/A

**County/Municipality:** N/A

**Project Summary:** N/A

**Nature of Problem(s):**

Many times, due to environmental regulations administered by the NJDEP, we are not permitted to impact the natural stream bed of waterways such as would be done with the construction of a box culvert. In many cases designers use traditional bridge designs which may not be the most economical.

**Recommendation(s):**

In order to meet environmental regulations and still provide the most economical design, designers are advised to look into alternatives such as the precast 3-sided rigid frame arch or precast structures when it is necessary to traverse a small waterway.

Designers should seek out more detailed application information and evaluate the suitability of this structures in conjunction with our construction requirements and needs.

Currently, precast 3-sided rigid frame and arch structures are being used for spans up to 42' and are becoming more and more popular with other States, counties, and local highway departments. This is attributed to the product's:

- Quick installation - shaving weeks off construction schedule and road closings
- Minimum disruption to stream bed during construction
- Design flexibility
- Lower costs

Consisting of precast or cast-in-place foundation and wingwalls and the precast 3-sided component sections, the system offers lower costs, fast and easy construction, and design versatility. In addition since the unit has no bottom, the natural condition of the streambed can be maintained throughout the installation. Attached are several examples of these types of structure.

**Implementation: *Immediately***

For additional information contact the Bureau of Quality Management Services.

**Impact Assessment:**

**Cost Impact:**

Schedule    Quality    Cost    Scope

Superseded

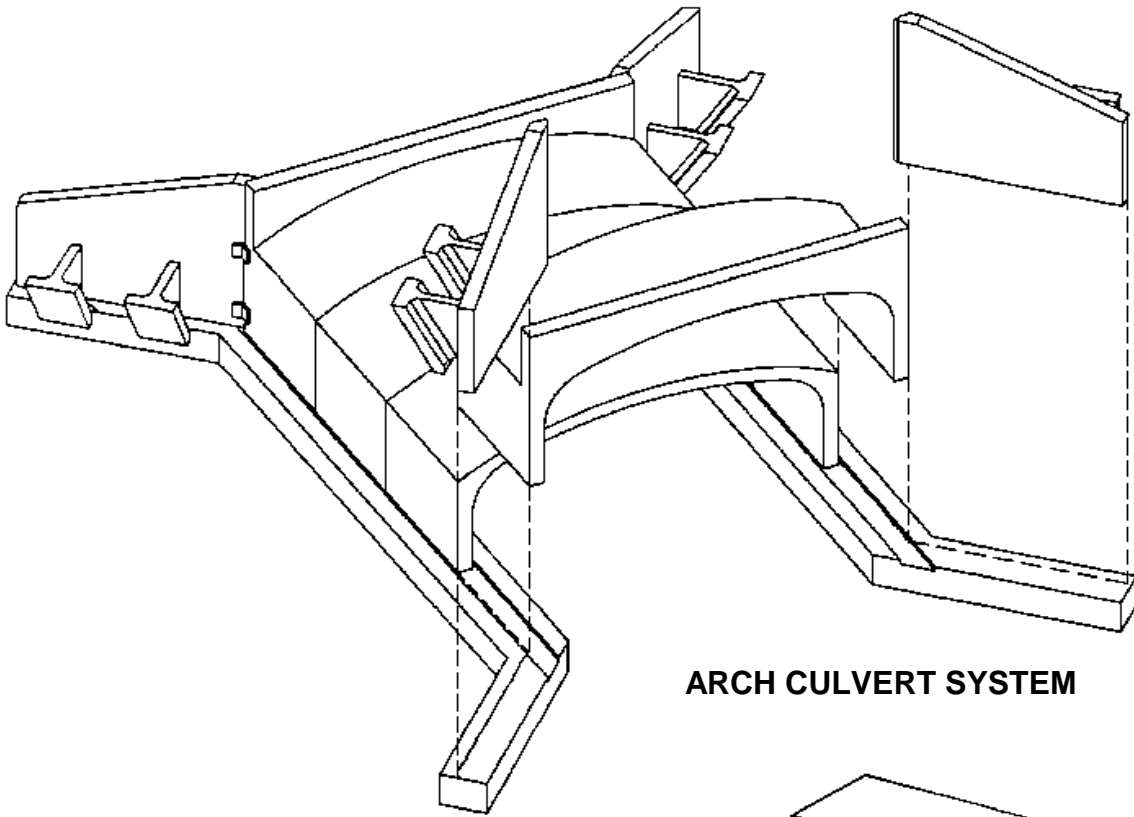

**ARCH CULVERT SYSTEM**

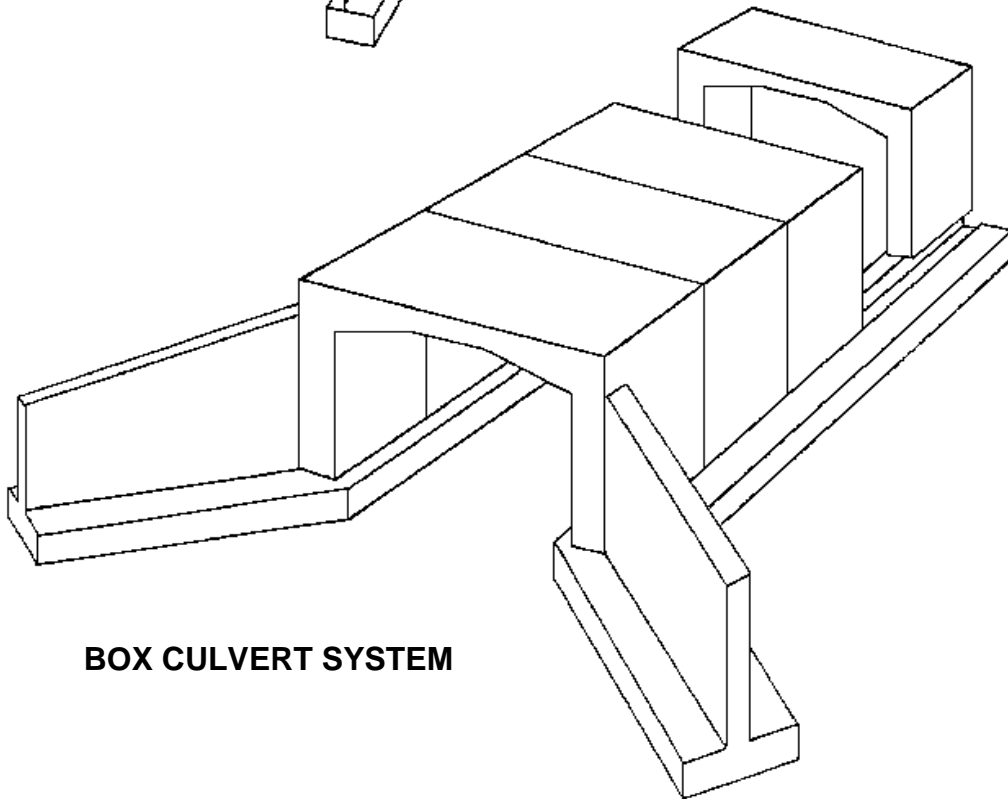

**BOX CULVERT SYSTEM**

**Three (3) Sided Rigid Frame Structures**

Superseded