

Fenwick Manor Rehabilitation and Stabilization

New Jersey Pinelands Commission Meeting
April 10, 2026

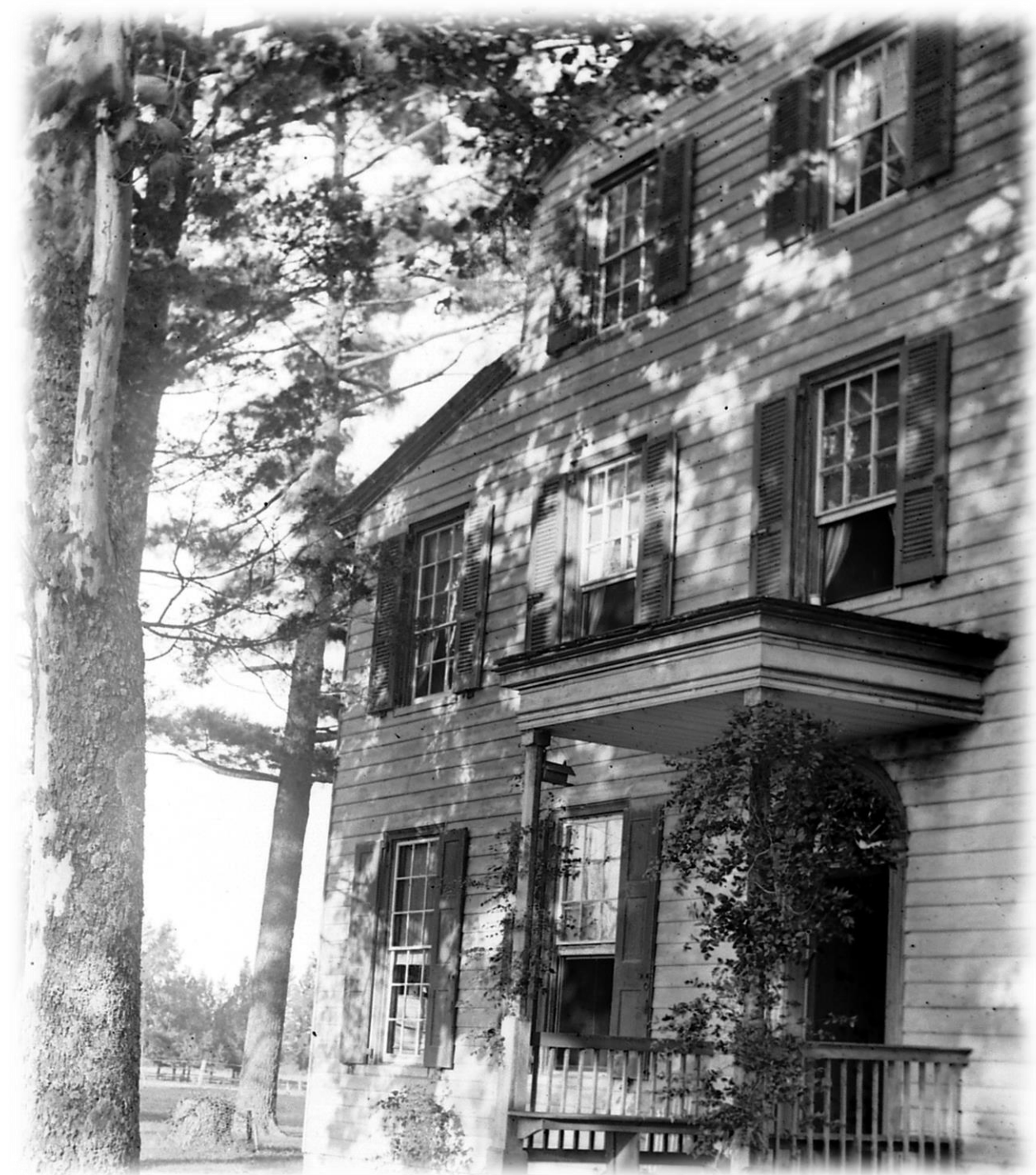

Scope of work

Foundation Stabilization

- Two front chimneys
- Brick piers
- Brick and stone foundations - mortar repair

Exterior Renovations

- Painting
 - paint removal,
 - surface prep/repair, and
 - repainting
- Window/shutter repair
- Improved drainage system
- Roofing

Foundation Stabilization



Trenches dug for HVAC in crawl space caused erosion under foundation



Cracks in wall due to slumping chimney

Inside fireplace showing slumping



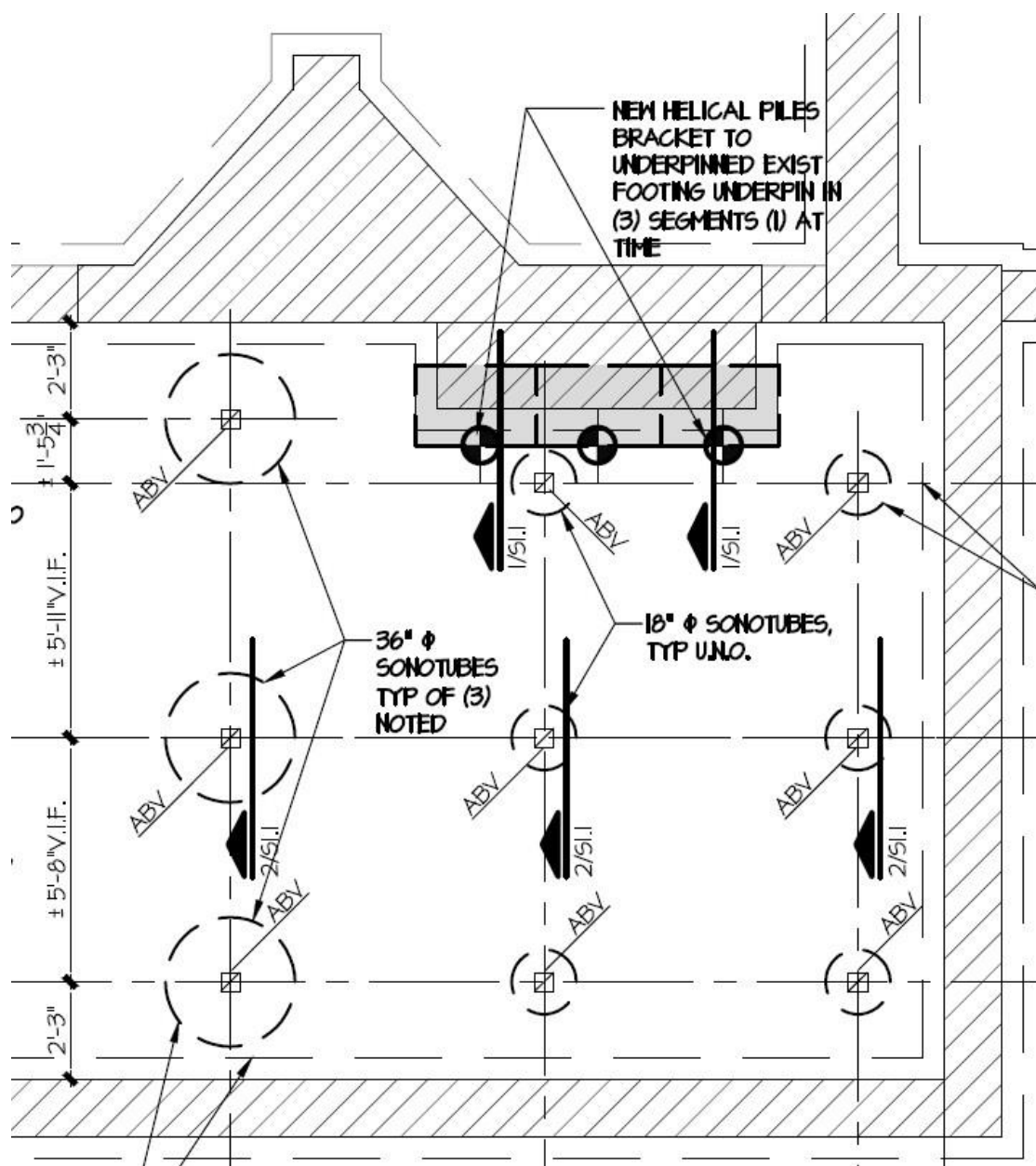

Chimney Foundation Plan

EXIST BRICK CHIMNEY TO REMAIN
 EXIST CONCRETE FOOTING, V.I.F.
 #5 BARS AT 12" O.C. EA WAY. HORIZ BARS SHOULD BE DOWELED INTO ADJACENT SECTIONS W/ 4" HILTI HY 200 EPOXY

HELICAL PIER BRACKET, RE: SCHED ON DETAIL 5 THIS SHEET. PROVIDE (4) 1/2" Φ EXPANSION BOLTS W/ 4" EMBEDMENT TO FOOTING

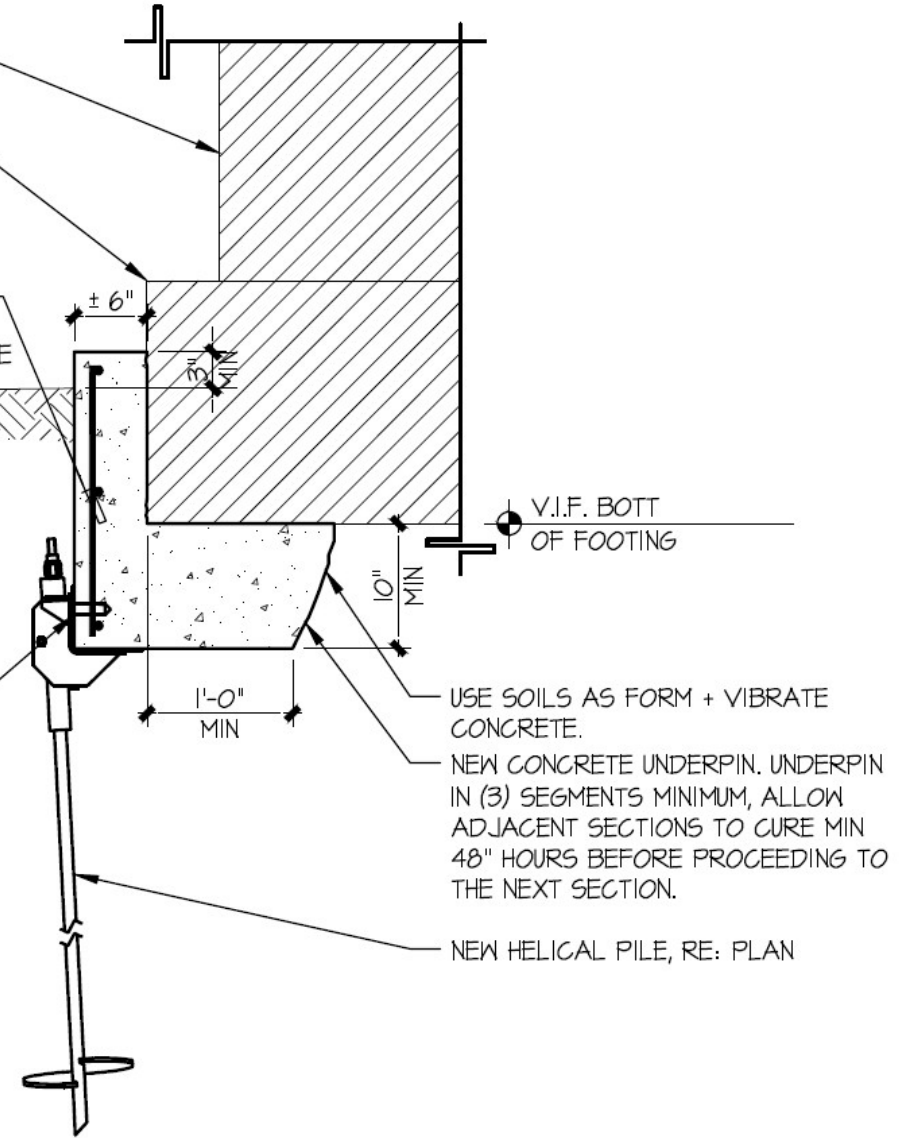

Helical Pile Design



Stone foundation mortar repair

Brick foundation mortar repair



Exterior Renovations



Front street view of Fenwick Manor

Wholesale peeling of paint





Repair and repaint windows/shutters and hardware replacement

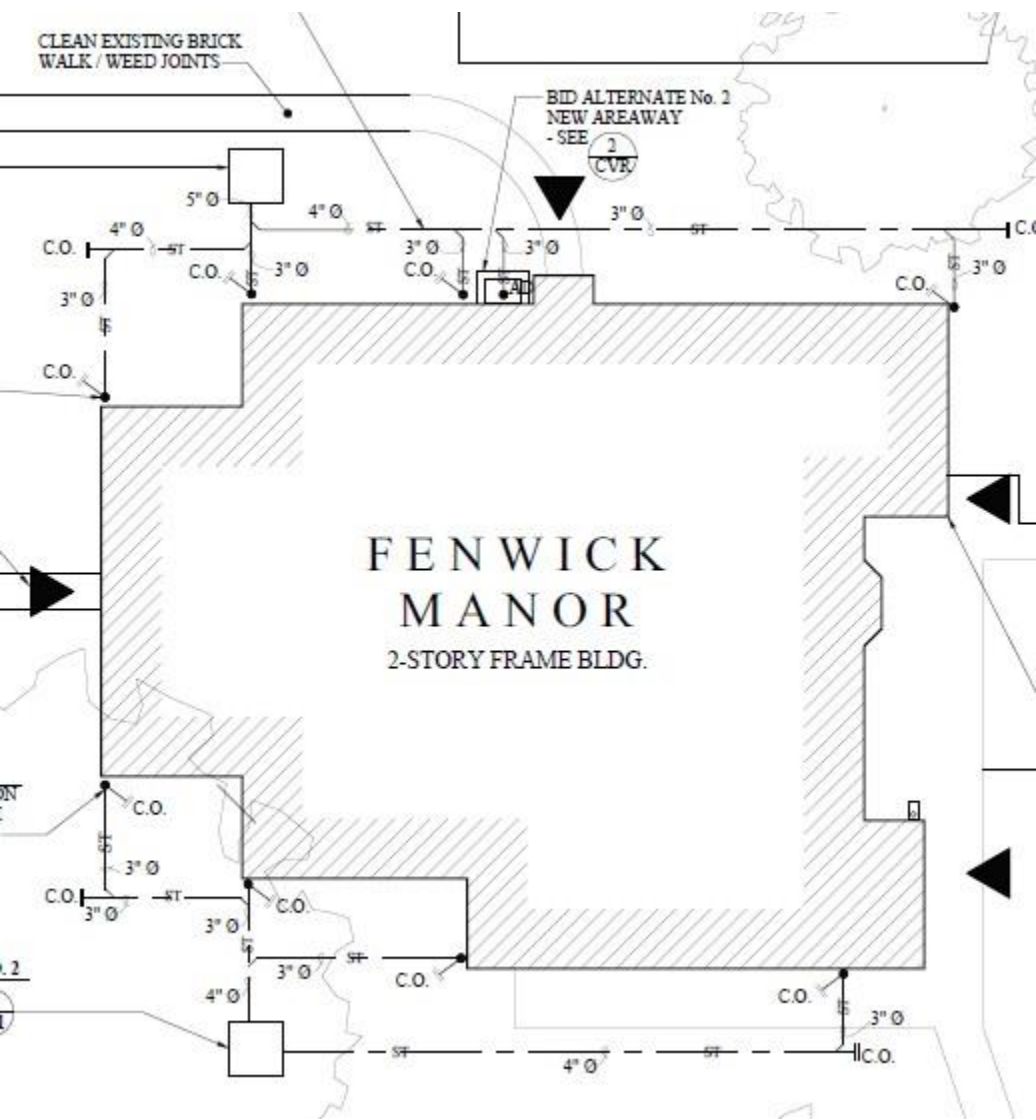

Underground drainage plans

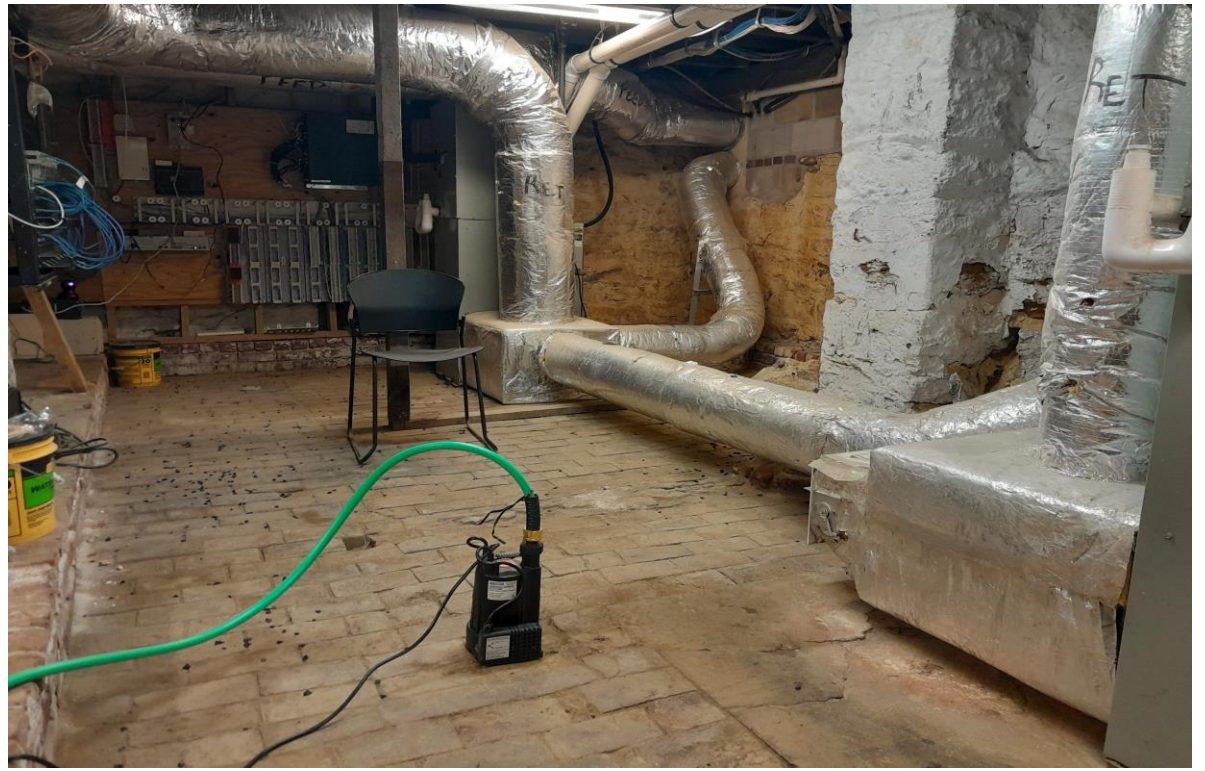

Submersible pump in basement

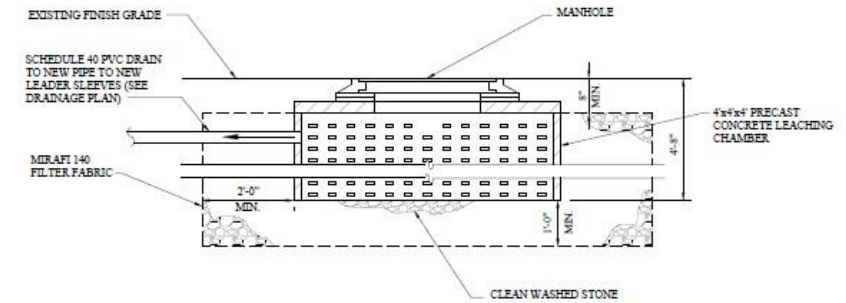
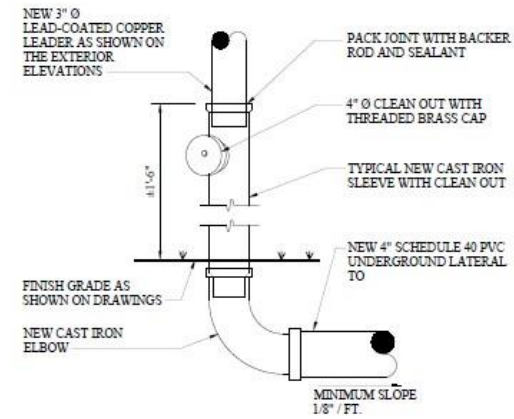

Hawley Bros Bid

Base Bid:	
General Req's	\$69,200.00
Temporary Facilities	\$6,400.00
Division 2 - Existing Conditions	\$16,732.00
Division 3 - Concrete	\$90,902.00
Division 4 - Masonry	\$78,900.00
Division 5 - Metals	\$7,800.00
Division 6 - Woods and Plastics	\$113,806.00
Division 7 - Thermal and Moisture Protection	\$158,650.00
Division 8 - Doors and Windows	\$79,950.00
Division 9 - Finishes	\$213,040.00
Division 10 - Specialties (Signs)	\$3,680.00
Division 23 - Heating, Ventilating, and Air Conditioning (HVAC)	\$33,985.00
Division 32 - Exterior Improvements (Drainage)	\$56,275.00
General Contingency Allowance	\$15,000.00
Allowances Per Drawings	\$10,000.00
Calculated Total:	\$954,320.00

Available Funds

Funding Source	Available Funds	Consultant/Contractor	Cost
NJ Historic Trust Capital Grant	\$575,000	Connolly & Hickey	\$102,100
		Hawley Bros	\$954,320
FY23 State Appropriation	\$500,000	Total Costs	\$1,056,420
FY26 State Appropriation	\$69,000	Totals	
Fenwick Manor Painting Reserve Fund	\$120,000	Total Available Funds	\$1,264,000
		Total Costs	\$1,056,420
Total Available Funds	\$1,264,000	Total Remaining Funds	\$207,580

Project Timeline

- March 17th – Personnel and Budget Committee meeting
- March 18th – Notice of Intent to Award
- April 10th – Pinelands Commission meeting
- Late April – Contract and building preparation
- Early May – Contract execution
- May – Notice to Proceed, upon acquisition of all necessary DCA permits (permit application submitted to DCA in late March)
- October – Construction completion within 150 days of Notice to Proceed

Thank you!

Questions?